



Discover the Safest Bumper Pull Trailer Designs from Double D Trailers

If a gooseneck trailer gives you goosebumps than a bumper pull horse trailer may be a perfect option.

Whether you are planning to tow with a small size SUV or a larger pick-up truck, these trailers are best for those who want to 'hitch up and go.' Safety is likely your biggest concern as you look at new bumper pull horse trailer. Here at Double D Trailers, we have the most innovative safety features on the market. Our goal is to create beautiful custom horse trailers designed specifically for your own personal needs.

Choose from a variety of straight load and slant load designs each packed with quality craftsmanship, individualized options, and safety features crammed in from hitch to bumper.

Our Top Benefits

Plenty of Design Options – If you can dream it, we can build it!
Choose from a wide variety of interior features and styles.

Custom Designs by Experts – Have your trailer built to suit your specific needs. Go ahead and challenge us! We can add square footage, customize horse features, and accommodate almost any request.

Top Safety Features - We are committed to building the safest bumper pull horse trailer to protect both you and your horses during travel. (Read more on the next page!)

Expert Advice for Hauling – Our towing specialist can help you determine if your vehicle is adequate to haul your new trailer. Plus, our trailers are available with weight distribution systems.

Variety of Models - Choose from our selection of bumper pull horse trailers for sale to haul from 1 to 4 horses. Or, check out our gooseneck horse trailers and living quarters horse trailers.

Flat Rate Nationwide Delivery – We can deliver anywhere in the US for a flat rate of \$395. Delivery can also be arranged for residents of Canada and Australia.

Trade-In Deals – We do accept trade-in deals so you can save money on your purchase.

Nationwide Warranty Service Program & Guarantee – If something isn't working with your trailer, we will send one of our trusted mechanics to your home to make it right.



Safety Features on Double D Trailers Bumper Pull Horse Trailers

Double D Trailers is different from the other brands because we put an enormous emphasis on safety. Features like SafeTack layout, Safe-Kick walls, Z-Frame structure, Rumber flooring, and SafeBump ceilings all work in harmony to protect both you and your horse during travel.



We think about the little things that will make a trailer feel like a safe space for your horse:

Is the trailer interior bright and airy?

Are the interior dividers firmly secure to prevent stressful rattles during travel?

Are the trailer materials and paint colors going to create a safe and comfortable interior temperature on the hottest of days?

Does the horse handler have room to safely maneuver around the horse during loading and unloading?

Is this trailer going to protect your horse in the case of an accident?

These are just a few of the questions we ask each time we create a custom bumper pull horse trailer for one of our customers.

Check out some of our safety features on the next page...

Top Safety Features on Our Trailers

SafeTack Design – Available on slant load models.

This design eliminates the dangerous narrow loading doorway found on other conventional slant load horse trailers. An enclosed and lockable tack storage area swings out like a second door to allow a full-width opening for loading and unloading.

SafeKick and SafeBump - Durable composite materials on the walls and ceiling will protect your horse from injury.



'Green' Design – We've nixed the use of many harmful chemicals in our manufacturing process.

Reverse Load Trailer Models – Studies have shown that there are benefits to backwards travel for horses. Check out our patented Reverse SafeTack horse trailers.

Tubular Dividers – Increase air flow and visibility with see-through tubular head dividers.

Quiet Interior – We've worked to eliminate interior rattles and transfer of road noise that can stress your horse.

100% Fully Insulated – Enjoy comfortable temperatures in both winter and summer months with full insulation from front to rear.

Rubber Flooring – Aluminum floors can corrode and weaken with time. This superior material provides lasting durability and easy cleaning. Plus, it reduces noise and vibration for your horse to lower stress levels and prevent excess leg fatigue.

Z-Frame Construction – Our patented design offers superior strength over aluminum to protect your horses in case of an accident. The 16 gauge Galvalite skin is 5 times stronger than 0.040 aluminum for an overall lightweight trailer.



Can't Decide Between a Slant Load & Straight Load Horse Trailer?

Each type of trailer configuration has its own advantages and disadvantages. First, think about how you plan to use your new trailer. How many horses are you planning to haul? Are you going to need a dressing room or tack storage area?

Straight load trailers tend to cost less and often allow more room for larger horses. However, many horses are hesitant (or can refuse) to “back out” of a straight load. Plus having to drop in a butt bar behind an unruly horse can be dangerous for the handler.

Our slant load horse trailers have eliminated many of the safety concerns typical for other brands. Since Double D Trailers specializes in custom horse trailers, these stalls sizes can be adjusted to fit your particular animals.

We've created the SafeTack design to eliminate the narrow (and 'scary') door found on most slant load designs. Instead, our SafeTack models have an enclosed tack storage area that swings out like a second door. This allows a wide open entry way for loading and unloading with additional escape doors and horse ramps available on the sides of the trailer.

Slant load horse trailers make better use of space with a shorter wheel base. It is often easier to include features like dressing rooms on these models while preserving driving maneuverability.

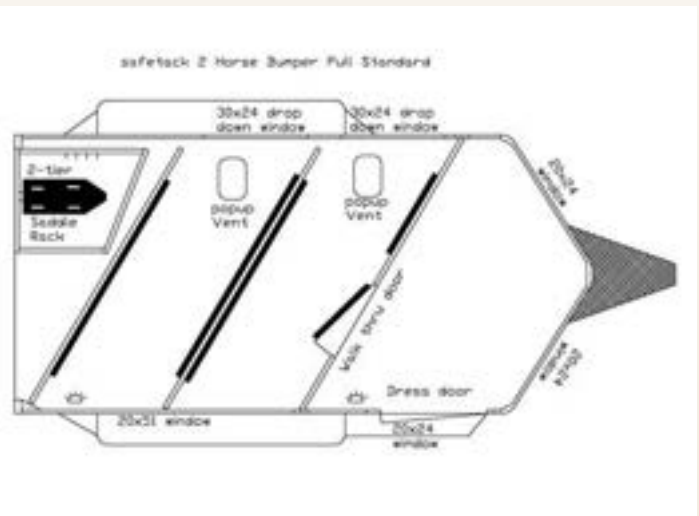

Forward Facing Safetack Slant Load

Check Out the Swing-Out SafeTack Compartment!

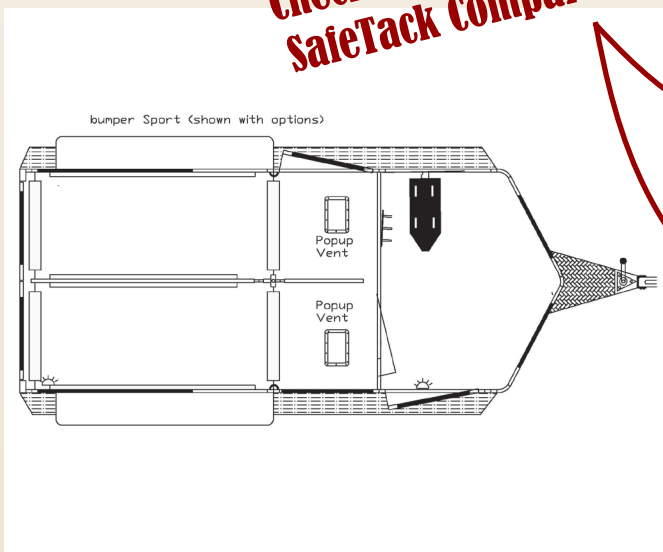

Traditional Straight Load

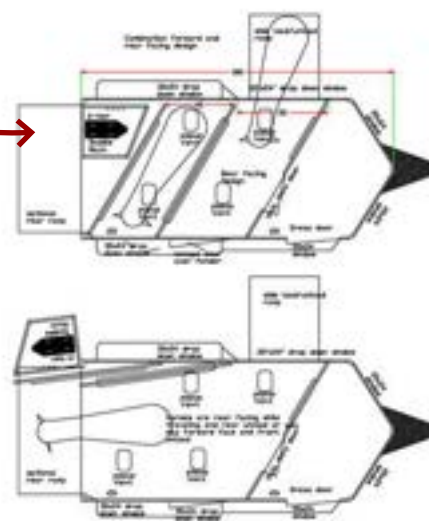

Reverse Safetack Slant Load with Side Ramp

Get Your Dream Dressing Room on a Bumper Pull Horse Trailer

Just because you only have a 2 horse bumper pull horse trailer doesn't mean you can't have a spacious dressing room.

Our designs allow for the addition of spacious front dressing rooms where you can store overnight supplies, show equipment, food, and chairs. Your saddles and sweaty blankets can be stored separately in the locked SafeTack storage area at the rear of the trailer. This will cut down on smell and leave you plenty of room for human comforts.

Customize your dressing room by adding extra hooks for a hammock or special equipment. You could even including a cot or mattress for hassle free camping. Add a roll out patio awning to transform your trailer into a mini shaded retreat for you and your horses.

If you are looking for full living quarters complete with plumbing and kitchenette, check out our living quarters horse trailers for sale.

NOTE: *We do not build bumper pull horse trailers with living quarters because they can be dangerous to haul.*

1 Horse Slant Load Dressing Room with Optional Mattress

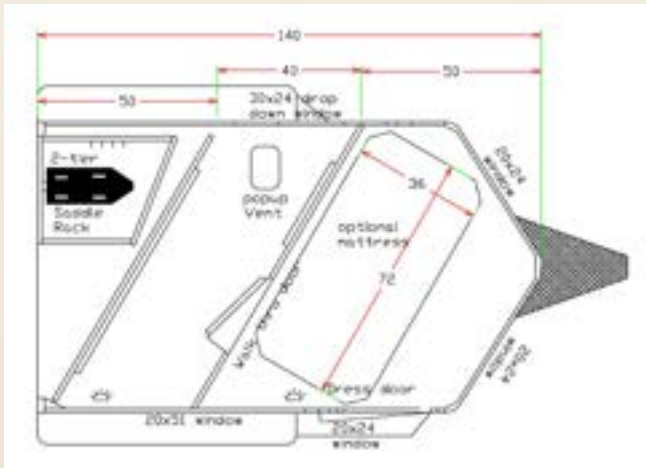

Hear From Happy Double D Trailers Customers

- 🌀 Nancy E. of Cedar City, Utah purchased a warmblood sized 2 horse bumper pull trailer with a dressing room. She shared..

Great, great service!! Although it was scary ordering on line (never having seen the trailer) but it is everything DD said and more!! Could not be happier with an “unseen” product.



- 🌀 Safety was a main priority in ordering a trailer for Christy I. of Atlanta, GA. She purchase a SafeTack 2 horse bumper pull trailer with a dressing room...



I LOVED all of the safety features and options that Double D has included. I wanted to know that my horse was as safe as possible on the road and I feel that Double D Trailers has created a very safe product that provides as much protection as I can get in a Bumper Pull.

- 🌀 Curt and his wife in Abilene, Kansas looked at a wide variety of brands before settling on Double D Trailers. When asked about their specific needs, Curt replied...

Safety, Safety, Safety....The fact that it was a really well built and great looking trailer was a plus too. The excellent customer service right from the beginning was incredible. We were kept updated constantly, and our needs were the priority not Double D's needs. We found that refreshing.



How to Get Started: Ordering a Custom Horse Trailer from Double D Trailers

Ordering your new bumper pull horse trailer from Double D Trailers is easy. You'll be connected quickly with our top designer, Brad Heath, to discuss your particular needs. Here are the basic steps for how to get started:

Step 1: Submit a Customization Request Online - Explore the trailer models at the top of this page under the slant load or straight load drop down menus. Click the 'View and Customize' button on any particular model to see a detailed overview, feature options, photos, videos, and floorplans. Once you've chosen a model, click the 'Customize Your Trailer' to select specific features and generate a summary. Fill out the form and click 'Submit.'



Step 2: Detailed Pricing Estimate - Once you submit your customization request. Our team will review your selection and look for any feature conflicts. For example, it is not possible to select both a front escape door and a manger. We will next send a detailed pricing estimate.

Step 3: Design Discussion with Our Experts - You will then begin an ongoing conversation with our experts to refine the design and establish the final pricing. We can help you add in special requests or remove unneeded features to stay within a budget.

Step 4: CAD Drawing - A highly detailed CAD drawing will act as the construction blueprint for our building team.

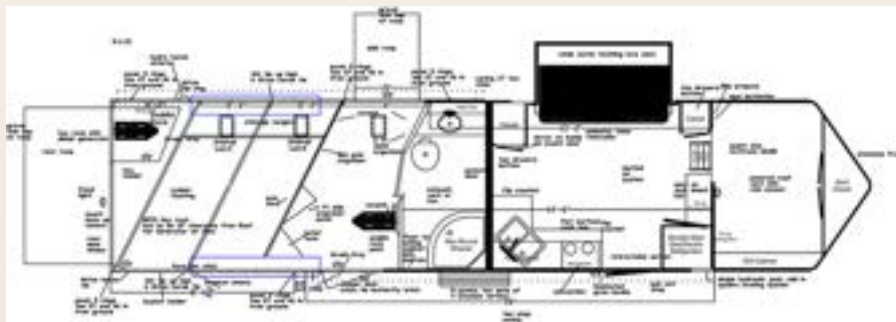

**Sample CAD Drawing of
Living Quarters Trailer**

Step 5: Approval and Start of Construction - Once you are happy with the final design, pricing, and order details, the estimate is converted to an official order. We will begin construction on your new trailer!

Step 6: Final Touches - Any decorative features like outside graphic and color can be determined after the trailer construction has begun. From here, you can sit back and relax until your brand new trailer is delivered to your driveway.

As we said....Easy, right?

SafeTack Slant Load 2 Horse Bumper Pull Horse Trailers

- Z-Frame® technology to create a durable and strong chassis.
- Unique, safe and functional rear SafeTack® technology
- Z-Frame® tubular head dividers to create more air flow and less stress on your horses.
- A convenient walk thru door from the dress to the horse area.
- SafeBump Roof® and SafeKick® Wall Systems to keep your horses protected.
- Reverse Haul Horse Trailer Design available.

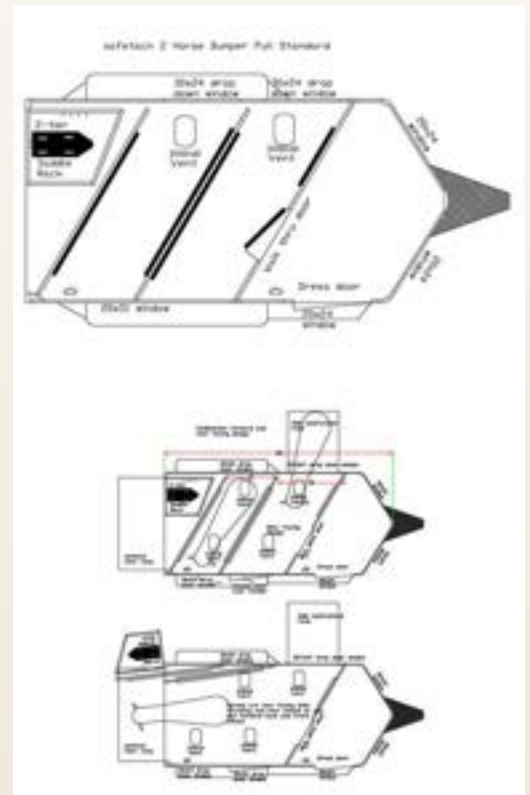

3 Horse Bumper Pull Slant Load Trailers

- Z-Frame® technology to create a durable and strong chassis.
- Unique, safe and functional rear SafeTack® technology
- Z-Frame® tubular head dividers to create more air flow and less stress on your horses.
- A convenient walk thru door from the dress to the horse area.
- SafeBump Roof® and SafeKick® Wall Systems to keep your horses protected.
- Rear facing Horse Trailer Design available (Often referred to as riding backwards).

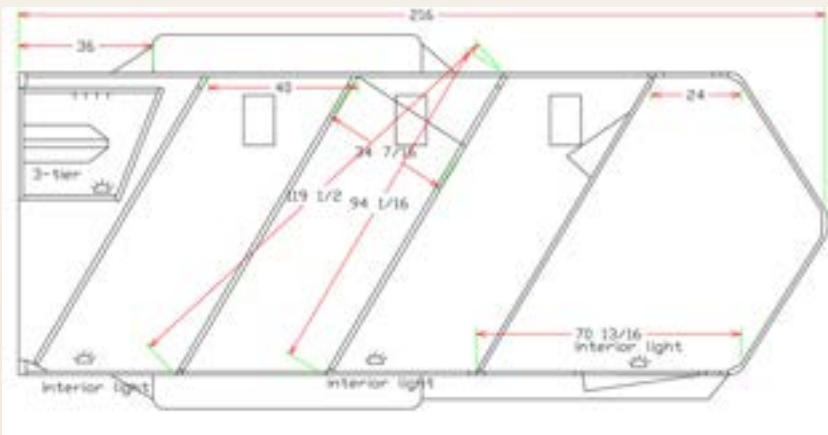

Bumper Pull 2 Horse Slant Load Trailers

- Z-Frame Technology
- Z-Frame® tubular head dividers to create more air flow and less stress on your horses.
- Barred head divider (more air flow, less stress on your horses)
- Full nose or V-Nose in the front walk in tack room
- Heat reflective roof and SafeKick® Wall System

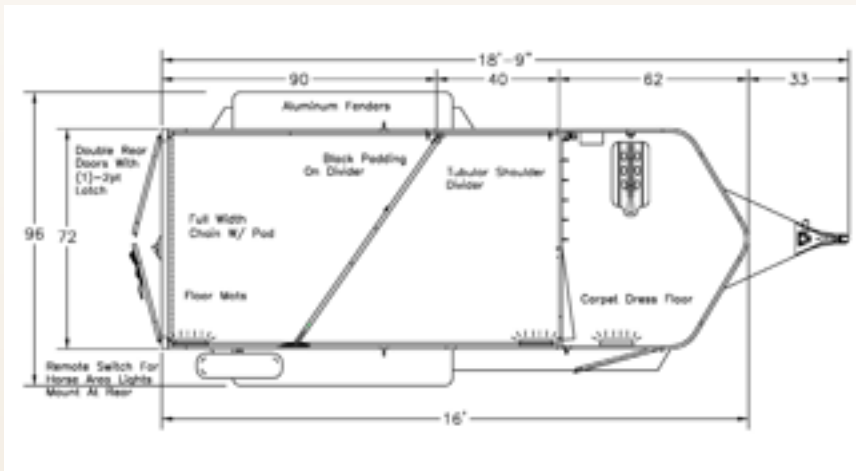

One Horse Trailer Bumper Pull

- The Safest One Horse Trailer
- Innovative and light weight
- Walk on and walk off feature
- Anti-kick divider standard (prevents you from getting kicked!)
- Potty door included
- Available for any size horse

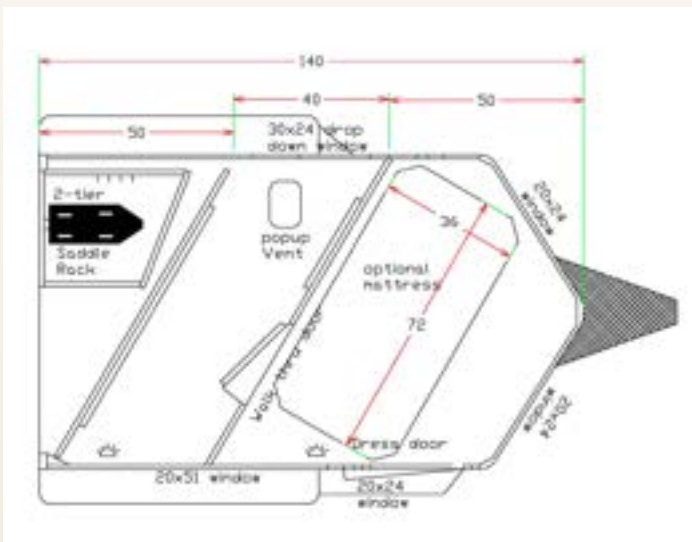

Bumper Pull Straight Load Townsmand Two Horse Trailers

- Z-Frame® technology to create a durable and strong chassis.
- Z-Frame® tubular head dividers to create more air flow and less stress on your horses.
- A convenient walk thru door out the front of your trailer
- SafeBump Roof® and SafeKick® Wall Systems to keep your horses protected.

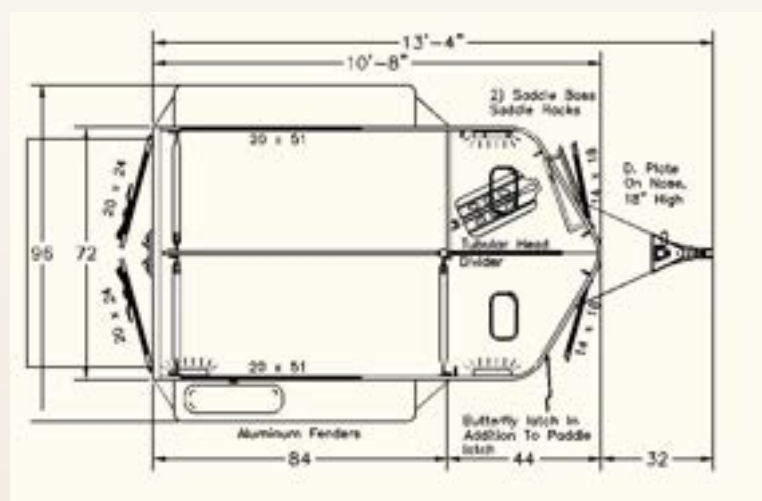

2 Horse Straight Load Bumper Pull Horse Trailers For Sale

- Z-Frame® technology to create a durable and strong chassis.
- Z-Frame® See Through tubular head dividers to create more air flow and less stress on your horses.
- A convenient walk thru door from the dress to the horse area.
- SafeBump Roof® and SafeKick® Wall Systems to keep your horses protected.
- Customizable to fit up to an 18 hand horse.

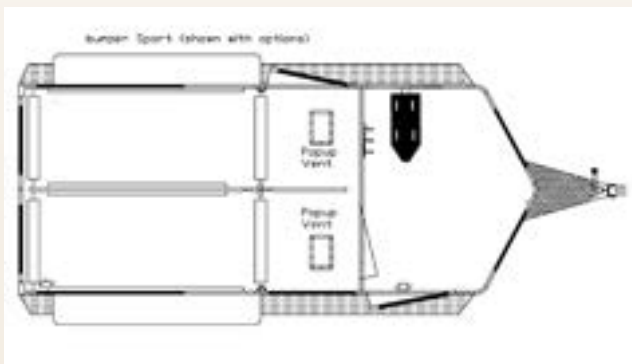

Bumper Pull V-Sport 2 Horse Straight Load Trailers

- Z-Frame Technology
- Z-Frame tubular head dividers standard (more air flow, less stress on your horses)
- V-Nose in the front walk in tack room
- SafeBump and SafeKick® Wall System

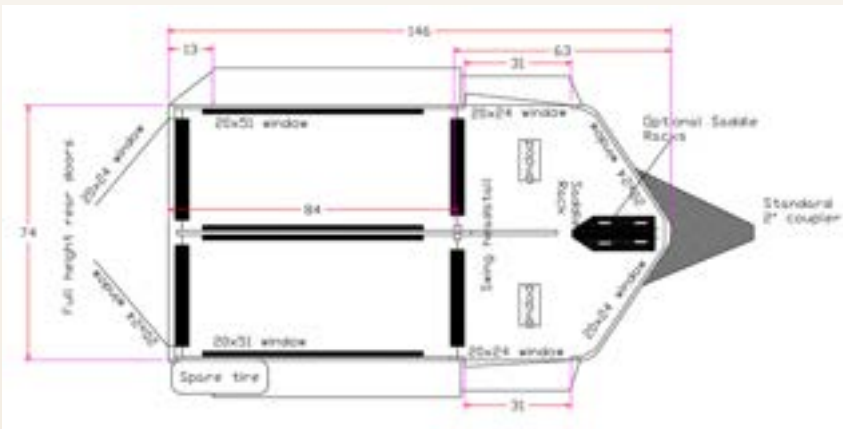

Bumper Pull 4 Horse Straight Load Trailers

- Z-Frame Technology
- Z-Frame Tubular see through head divider standard (more air flow, less stress on your horses)
- V-Nose in the front walk in tack room
- One piece self insulating fiber composite Safebump Roof® and SafeKick® Wall System

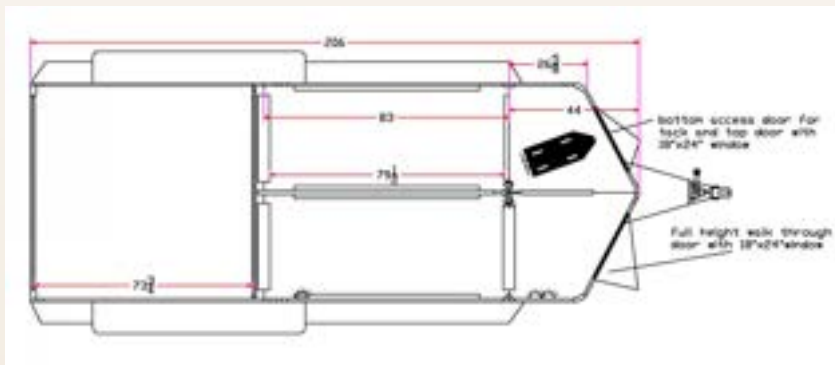

Bumper Pull Live Stock Trailers

- For hauling cattle, sheep, goats or other livestock, as well as horses
- Z-Frame Technology on 16" centers for durability
- One piece fiber composite self insulating Safebump roof system
- 16 Galvalite heavy duty interior lining

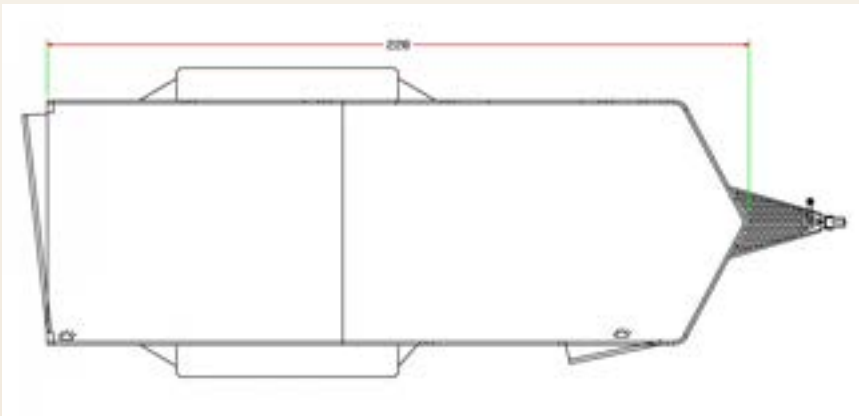

Bumper Pull Adventurer 2 Horse Straight Load Trailers

- Z-Frame Technology
- Z-Frame straight divider (light weight easy to remove, strong and safe)
- Tubular see through head divider (more air flow, less stress on your horses)
- Unique tack storage feature Full height side exit door (makes loading safe for you)

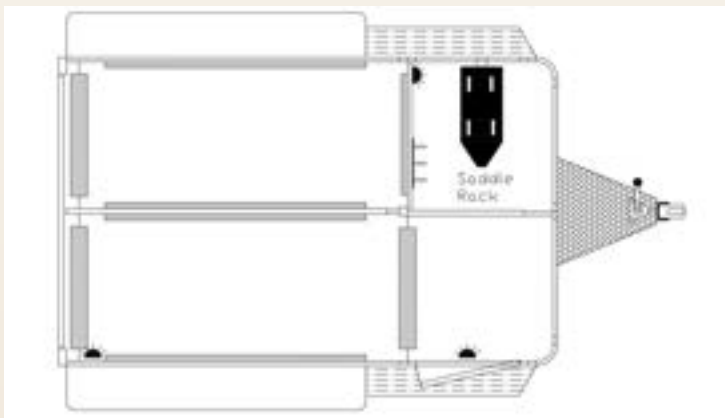

Top Features on Bumper Pull Horse Trailers

Options:

- Z Frame Technology
- 2"x 8" Pressure Treated Pine Flooring on 16" Cross Members
- Rubber Flooring
- Walk Thru Door to Horse Area in slant wall (specify location and direction of swing)
- EZ Lube Durable Never Adjust Brakes
- Full Height Rear Doors with SafeTack Design
- 24" Diamond Plate Gravel Guard at Nose
- Running Board Step Down Dressing Room Side
- Carpet in Dressing Room Floor
- SafeTack® Slant Load Design, allows for entire back of trailer to be open for loading and unloading. Very safe
- Marker Lights on Fender
- Extra divider on rear stall to prevent horses from backing out when rear doors are opened
- Spare Tire inside dressing room
- Z-Frame Slant dividers with handmade padding and safety slam latches
- Horse Area Roof Vents, one per stall aluminum
- Custom handmade padding on dividers and slant wall
- 30" Dress Door Factory Built Door
- SafeKick® Wall System
- Heat reflective SafeBump® Roof System in new leak proof fiber composite material
- Insulated side walls in horse area for maximum temperature protection and safe, quiet ride
- Floor Mats in Horse Area
- Horse Area Roof Vents (One Per Horse)
- Rechargeable Emergency Breakaway System
- 7-Pin RV Style Plug
- Warranty on Structure, Bumper-to-Bumper, Non Double D Manufactured Parts

Please see individual online model descriptions for specific features, warranties, and pricing.



Ready to Start Designing Your New Custom Trailer?

START TODAY!

Visit www.doubledtrailers.com to begin browsing the bumper pull horse trailer models available. Simply click **“View and Customize”** to start designing your trailer.

As always, feel free to contact us at www.doubledtrailers.com/contact-us/ with any questions.

